

AVAS0994 "CARTESIO W" Vasca in Cristalplant® e legno / Cristalplant® and wood Bathtub

DATI TECNICI / TECHNICAL DATA

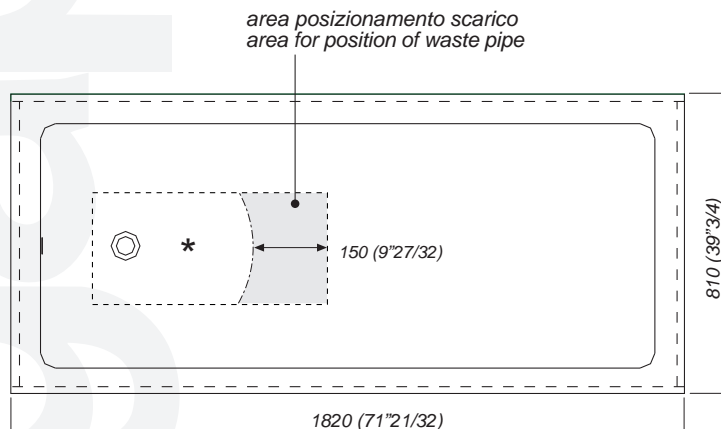
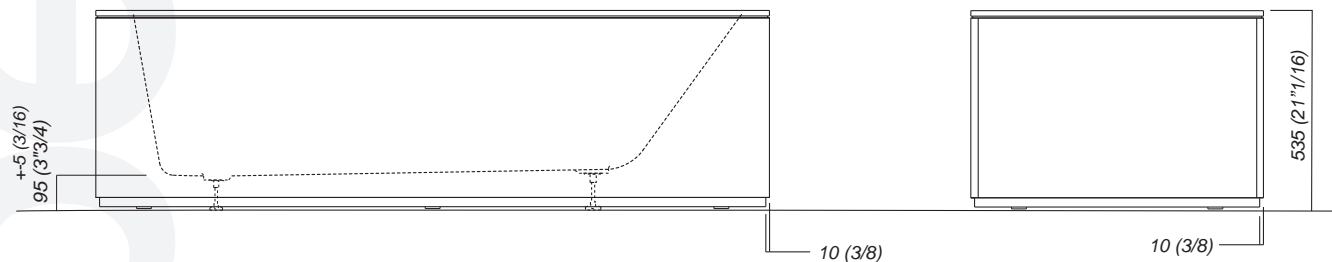

* Se si prevede l'utilizzo del pozzetto AKITPZVAS attenersi alle istruzioni allegate.
When using the recess AKITPZVAS please follow the instructions attached.

PREINSTALLAZIONE / PREINSTALLATION

La vasca "Cartesio" deve essere installata su un pavimento perfettamente piano.
E' necessario predisporre a pavimento un pozzetto
N.B. Evitare di realizzare impianti di riscaldamento nell'area sottostante la vasca.
The "Cartesio" bath tub must be positioned on a flat floor surface.
It is necessary to prepare a recess in floor.
Note: Avoid the installation of floor heating plants in the area under the bathtub.

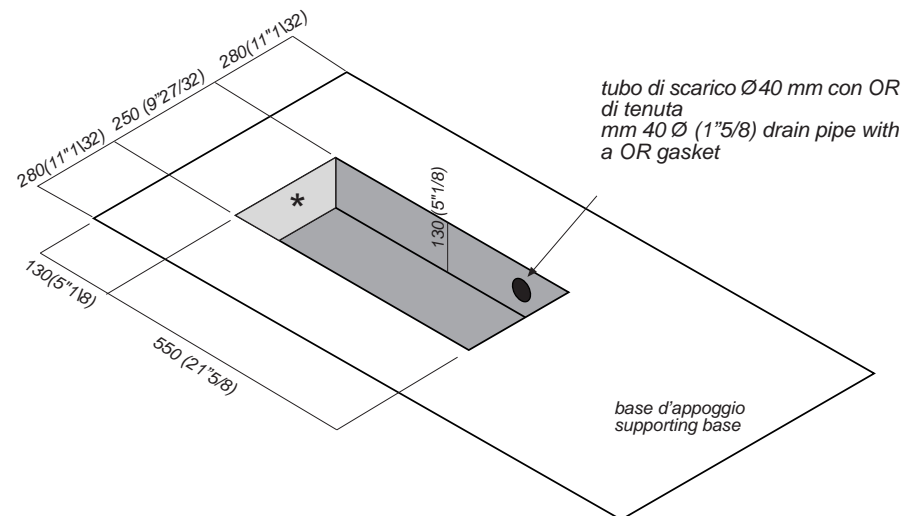

AVAS0994 "CARTESIO W" Posizionamento rubinetteria Agape / Positioning Agape taps

istruzioni di montaggio / assembly instruction

PIANTANE DA TERRA / FREESTANDING SPOUT

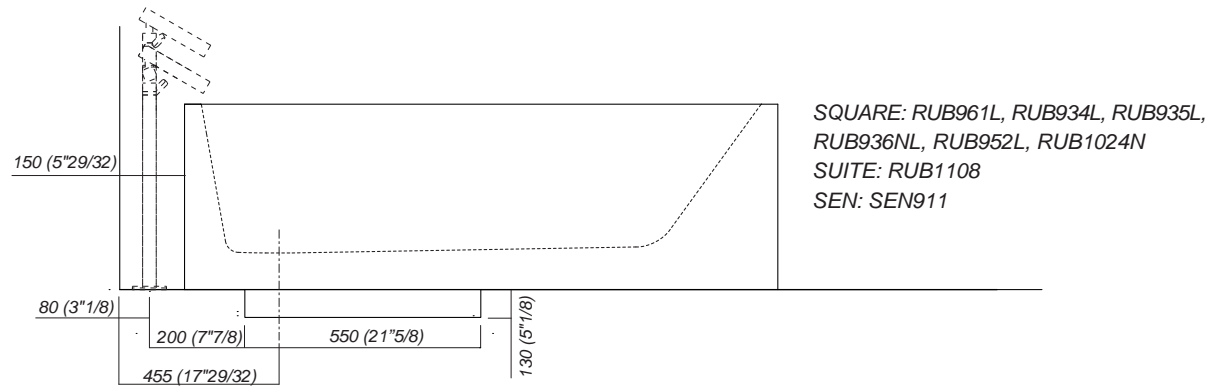
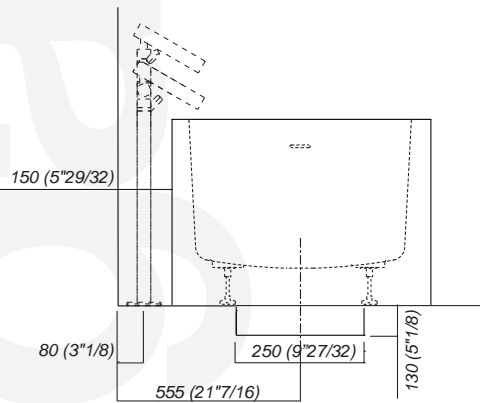
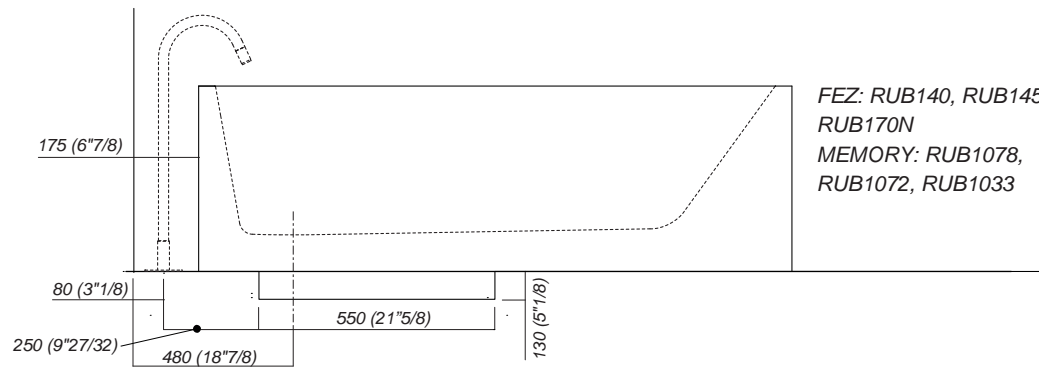
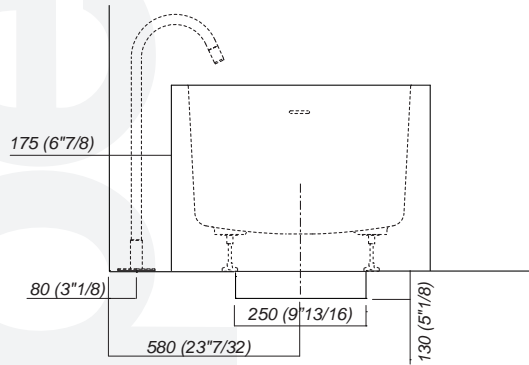

COLONNA PORTA RUBINETTERIA / FREESTANDING COLUMN

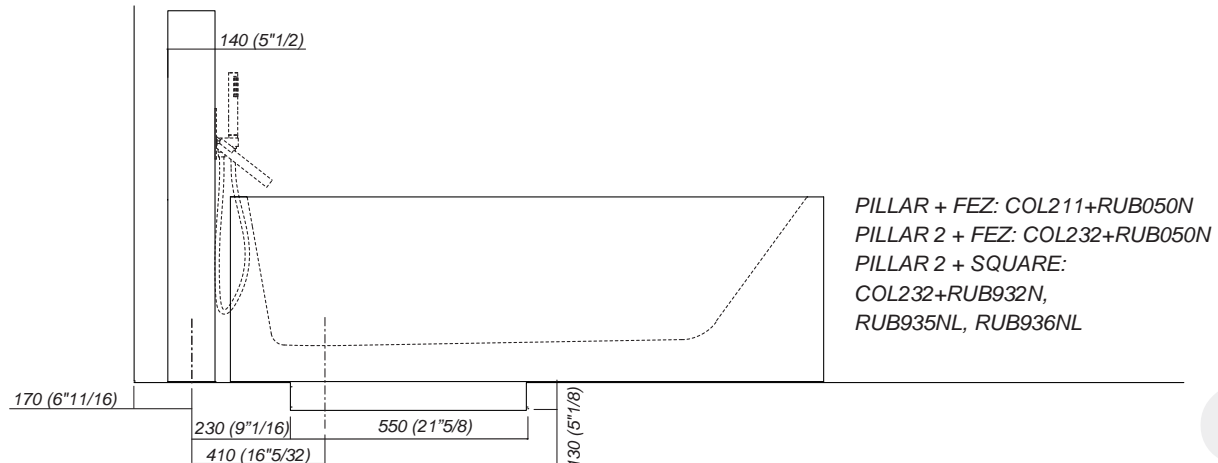
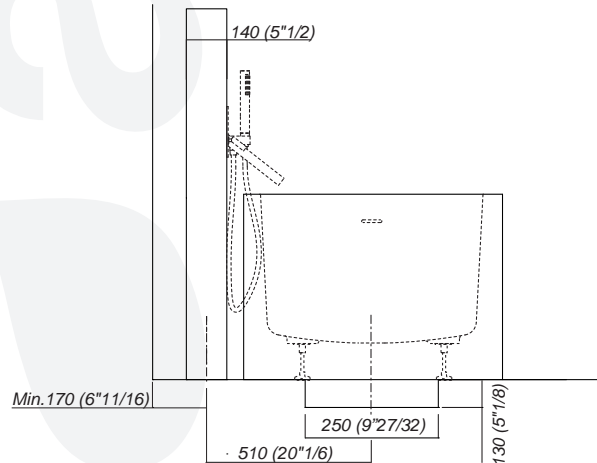

AVAS0994 "CARTESIO W" Vasca in Cristalplant® e legno / Cristalplant® and wood Bathtub

ESPLOSO STRUTTURA / PRE-ASSEMBLED STRUCTURE

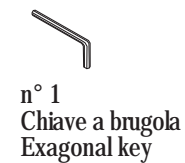
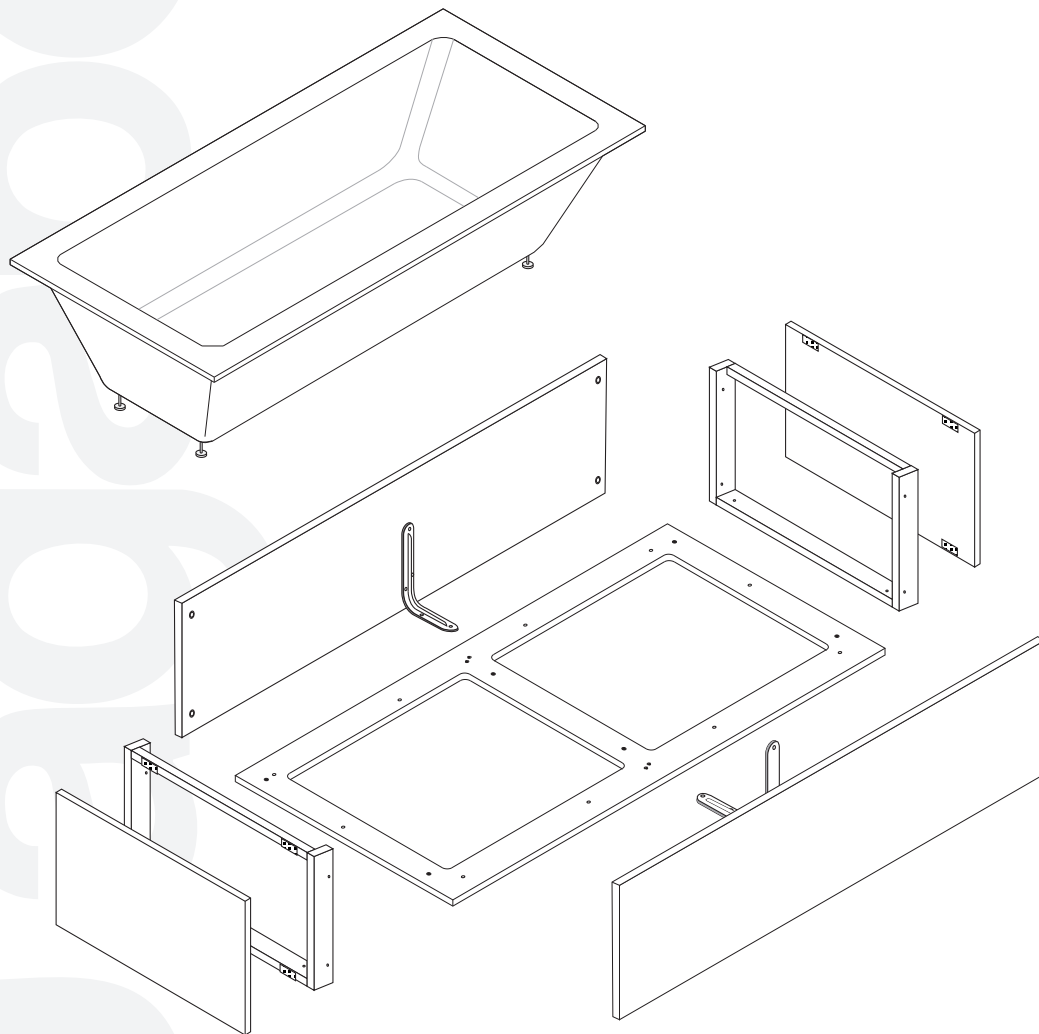

STRUMENTI/ TOOLS

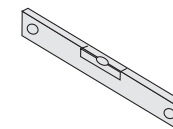

3

AVAS0994 "CARTESIO W" Vasca in Cristalplant® e legno / Cristalplant® and wood Bathtub

INSTALLAZIONE / INSTALLATION

1

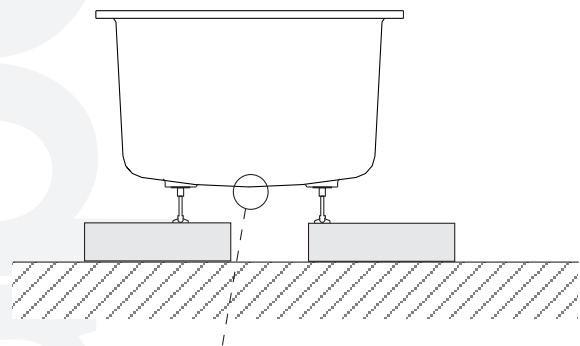

Collegare il sifone, la piletta e il troppo pieno.
Connect the drain trap, the waste and the overflow.

3

Posizionare e livellare il basamento.
Position and adjust the base.
Inserire una prolunga di scarico e collegare i tubi di adduzione.
Insert a drain extension the water supply pipe.

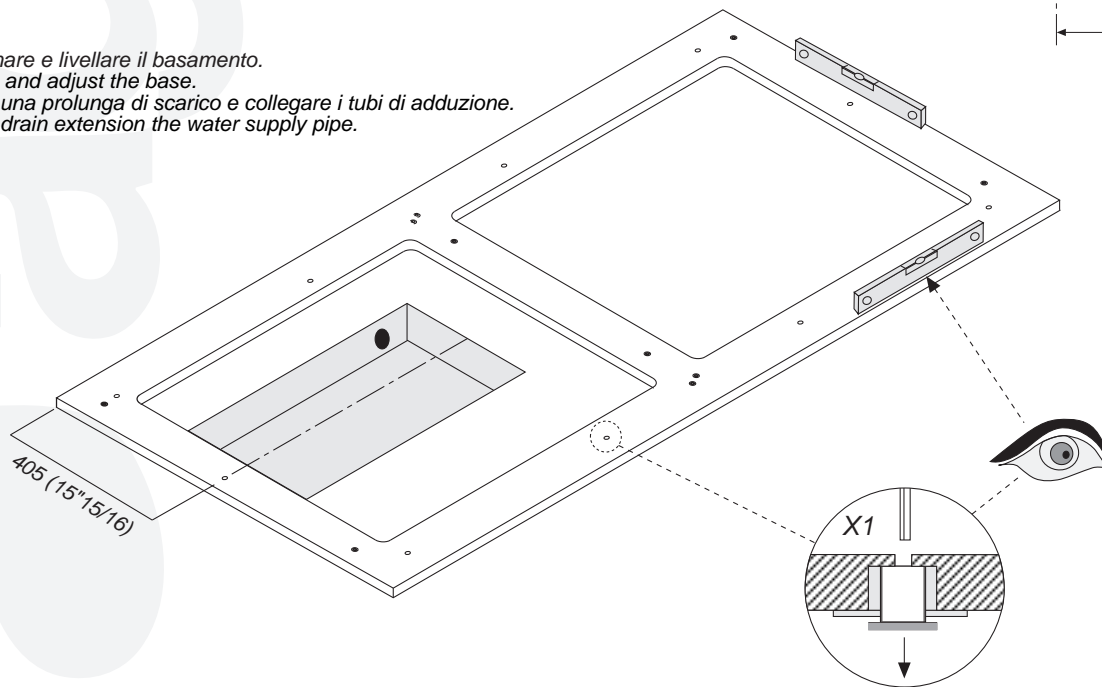

PARTICOLARE PILETTA / DRAIN DETAIL

2

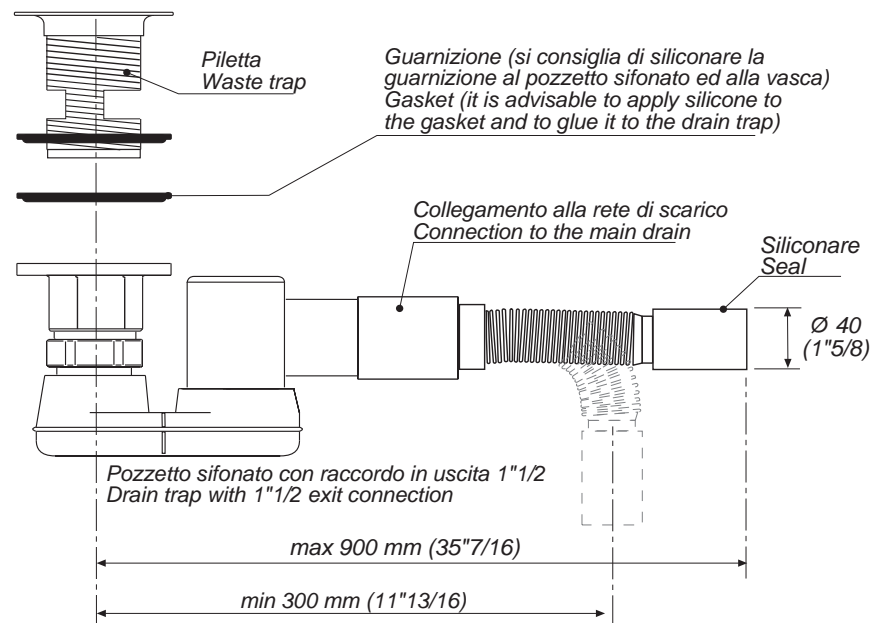

AVAS0994 "CARTESIO W" Vasca in Cristalplant® e legno / Cristalplant® and wood Bathtub

istruzioni di montaggio / assembly instruction

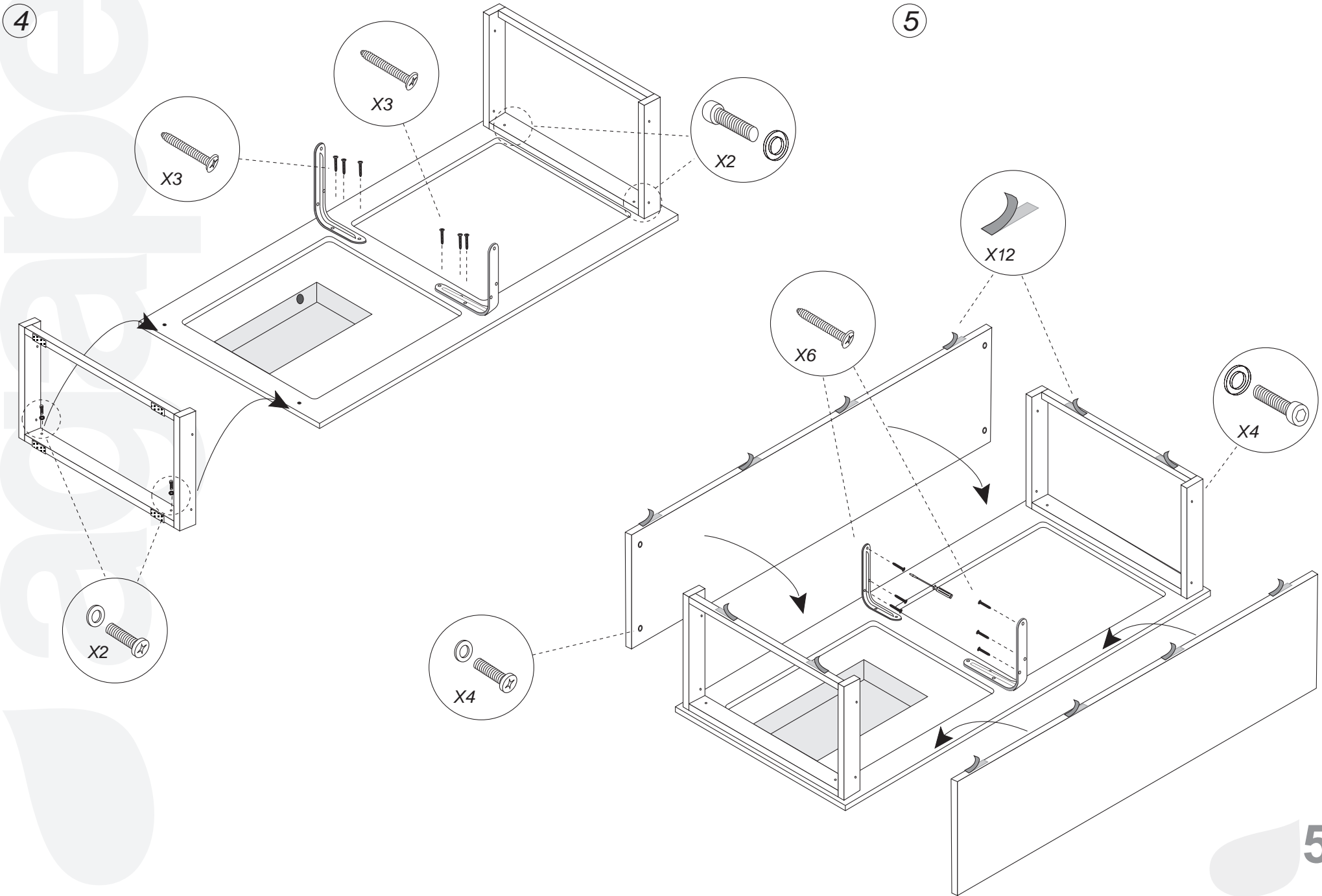

AVAS0994 "CARTESIO W" Vasca in Cristalplant® e legno / Cristalplant® and wood Bathtub

6

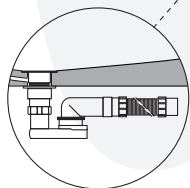
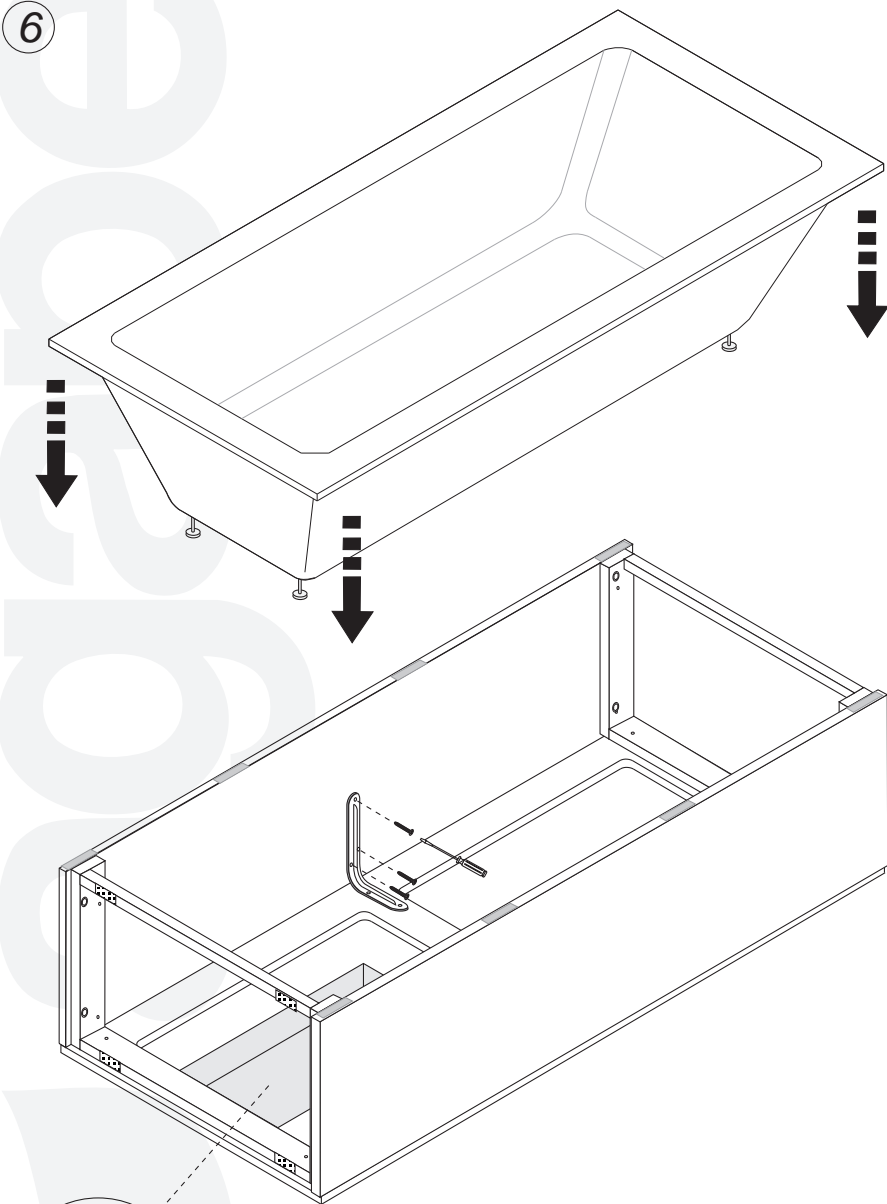

Collegare lo scarico e l'adduzione.
Connect the flexible pipe and and .

7

Effettuare alcune prove di tenuta dell'impianto realizzato.
Test different times the seal of the realised plant.

