

# AGAPECASA

## Tavoli/Tables - Compensato

agape srl - Via Po Barba, 69 - 46031 Bagnolo S/Vico (MN) Italia tel. 0376/250311 - www.agapedesign.it - Cod. 10183 - 10/2010 istruzioni di montaggio / Instructions for installation

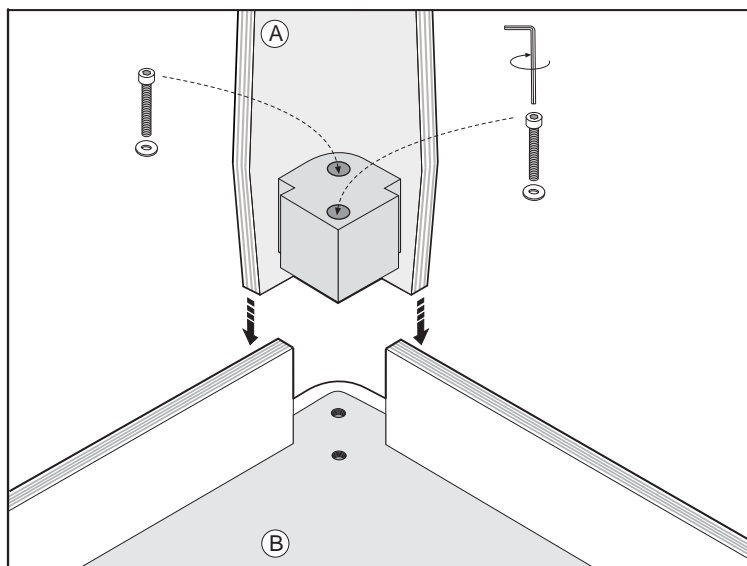

### Elenco delle parti / List of components

- A piano / top
- B supporti / legs
- C ferramenta / fittings

### Rovere/Oak - Teak

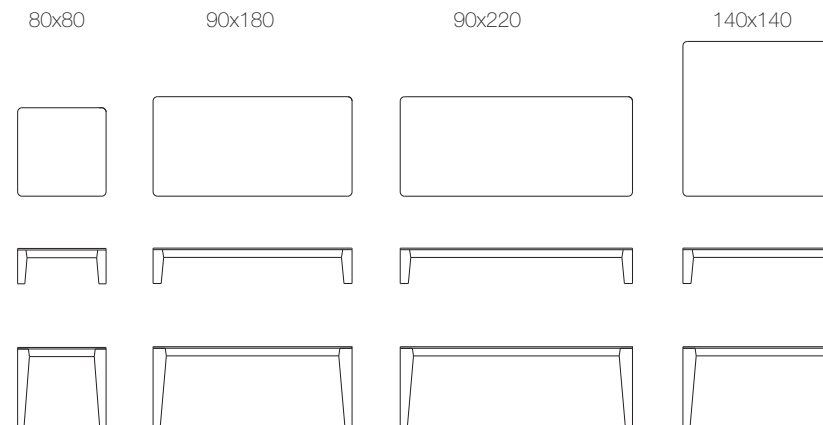

### C Ferramenta/Fittings

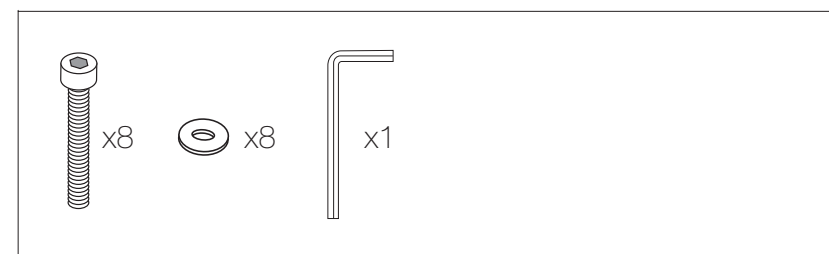

### Nota bene / Please note

L'utilizzo dei tavoli è strettamente legata alla sua funzione. Non è possibile salire o sedersi sul piano.  
 Tables are to be employed just as that. It's not possible to stand or sit on them